

Component Layout Top

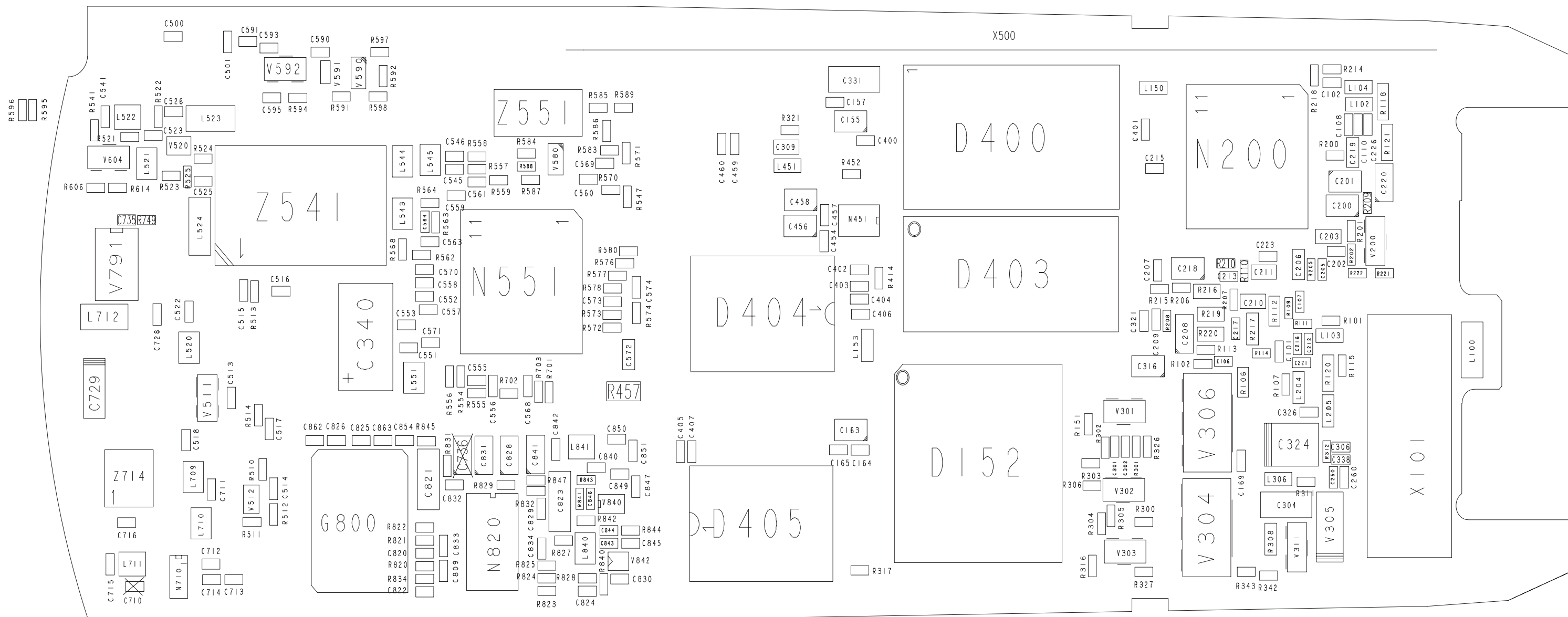

Component Layout Bottom

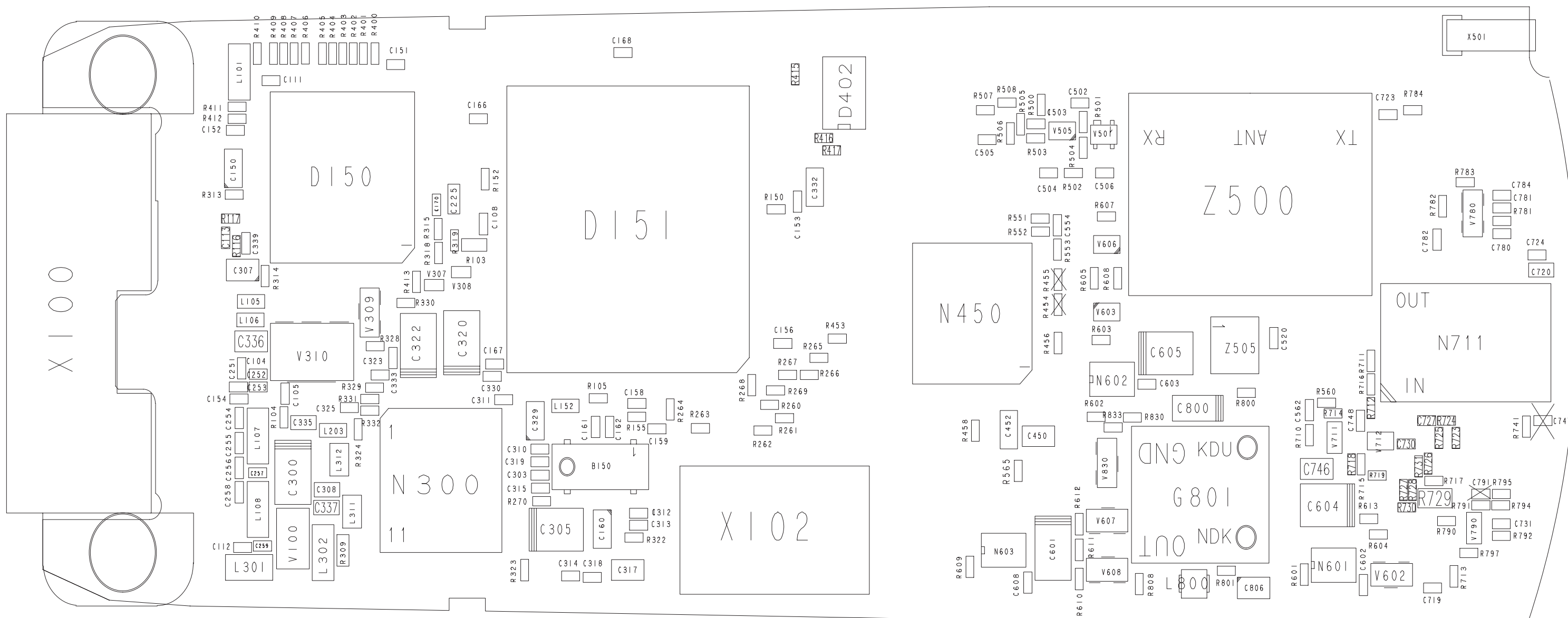

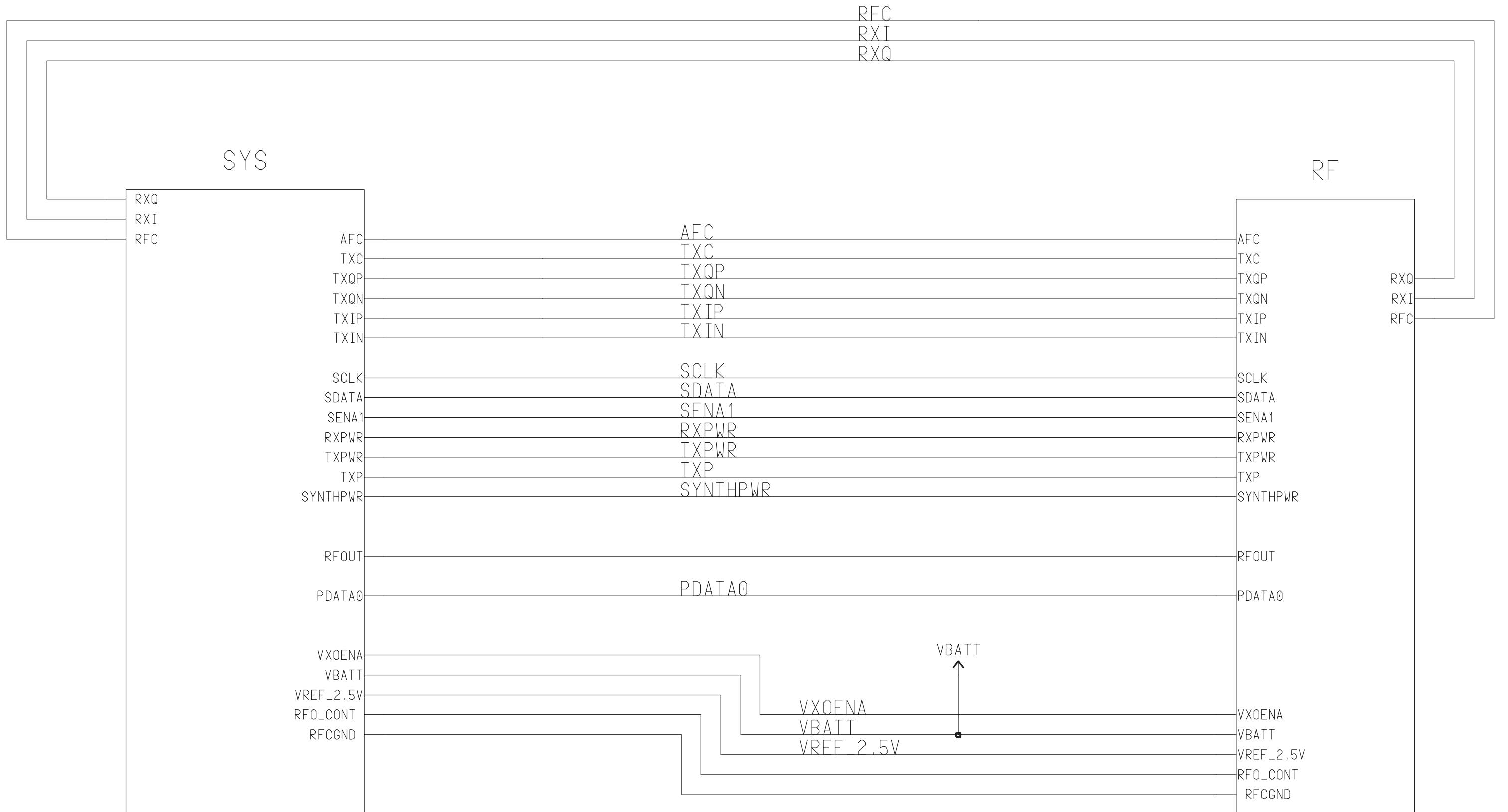

RX/TX Block Diagram v.1 ed.117

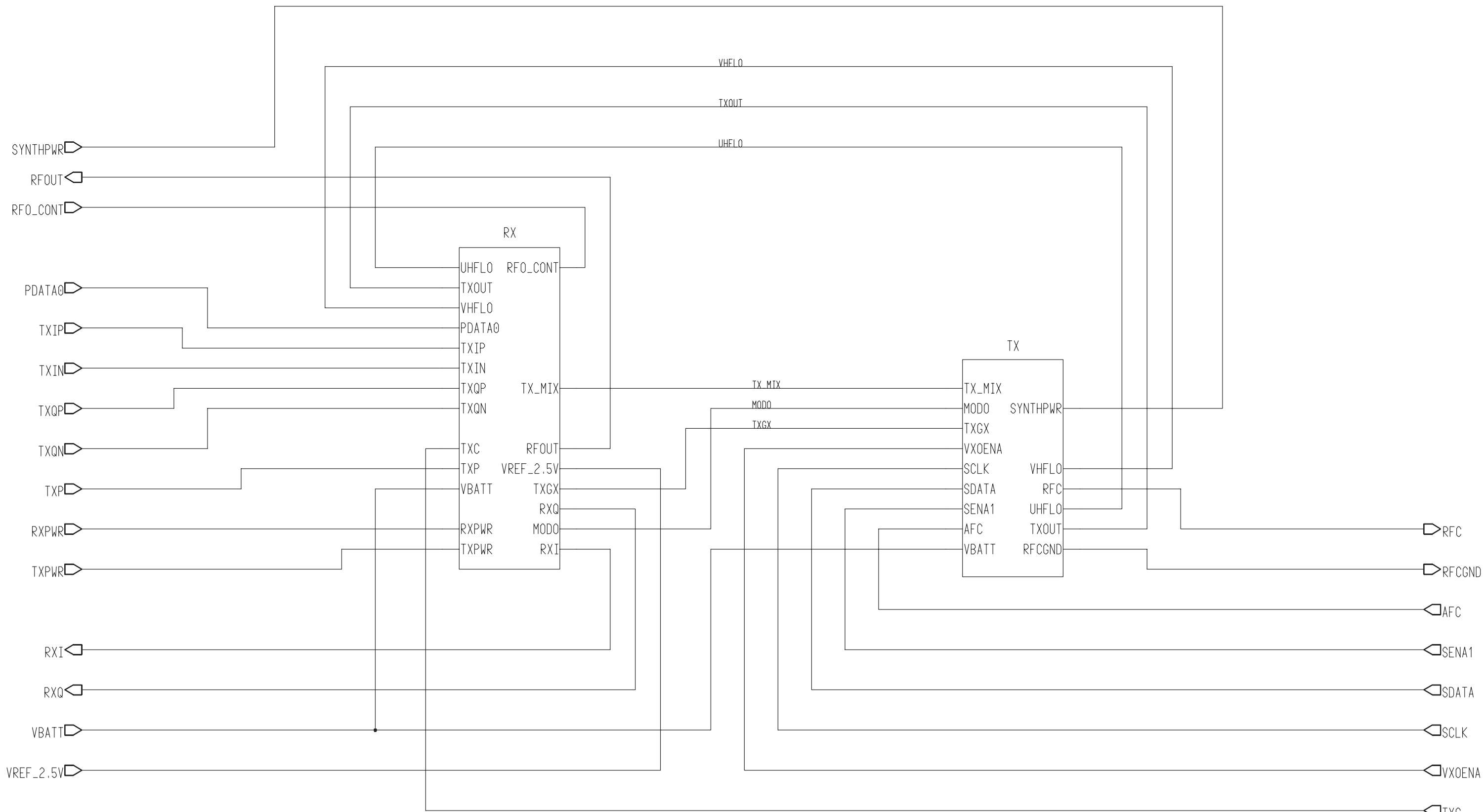

RX Circuit Diagram v. ed.20

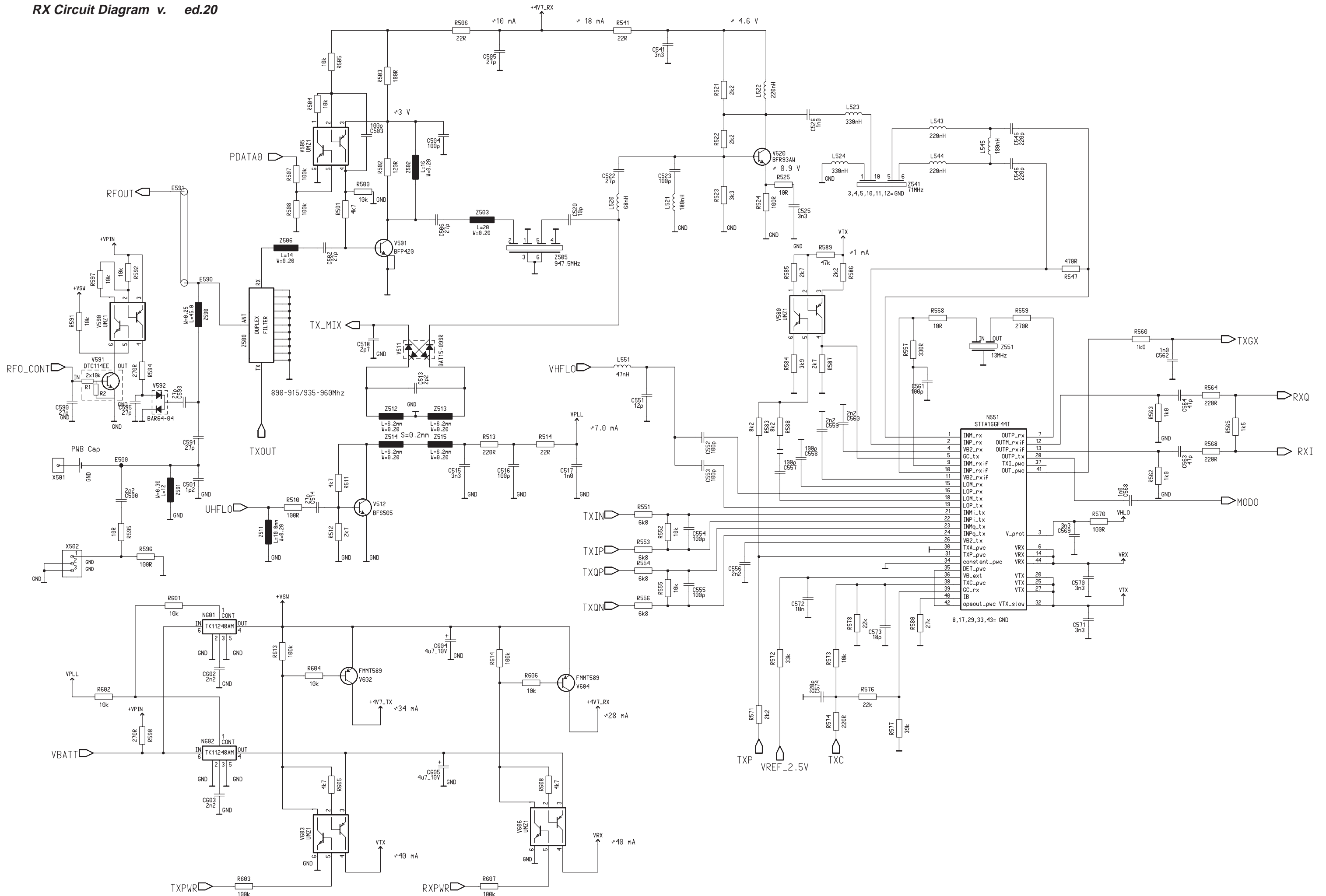

TX Circuit Diagram v. ed.486

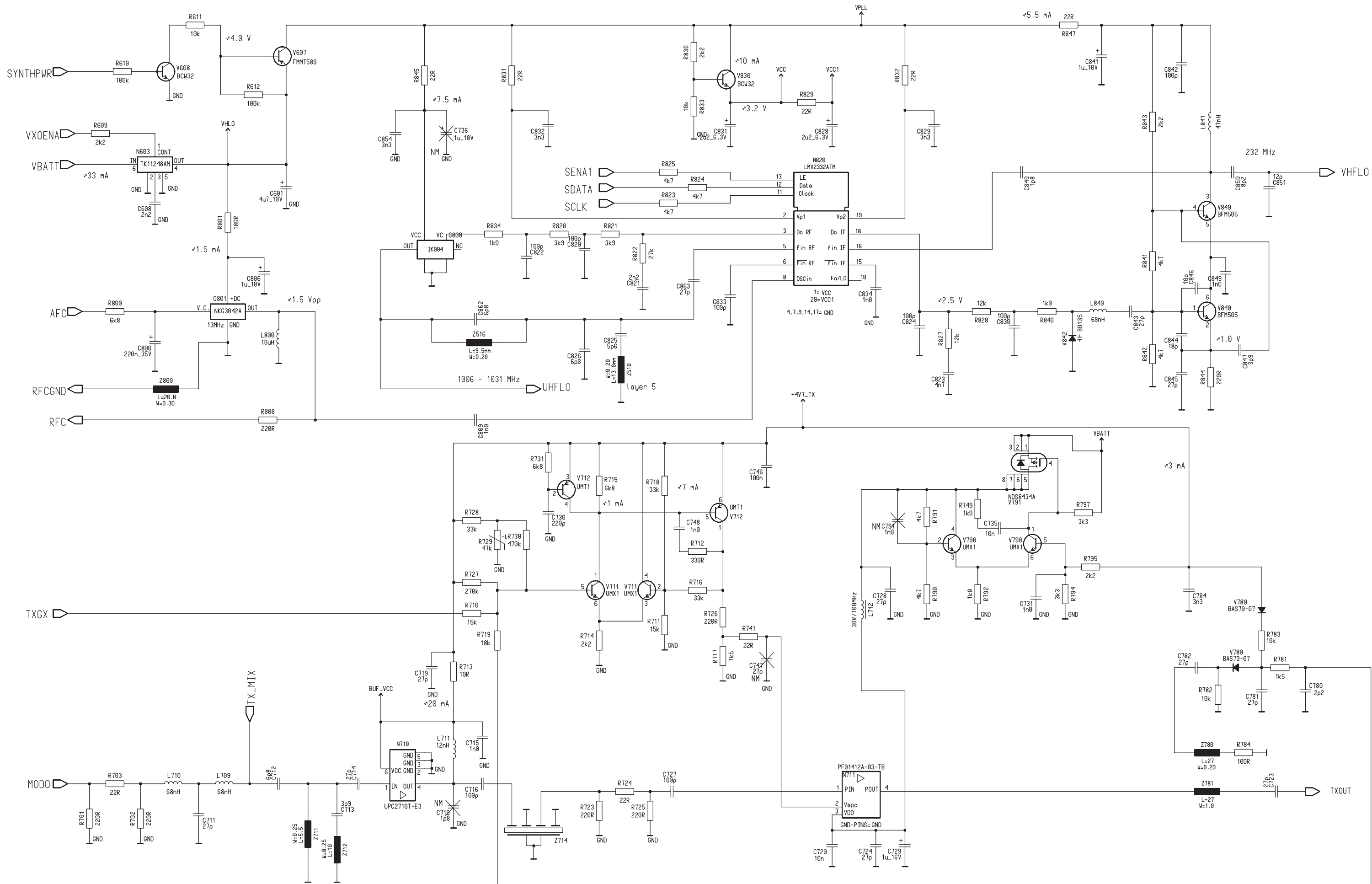



Audio Circuit Diagram v.3.5 ed.20

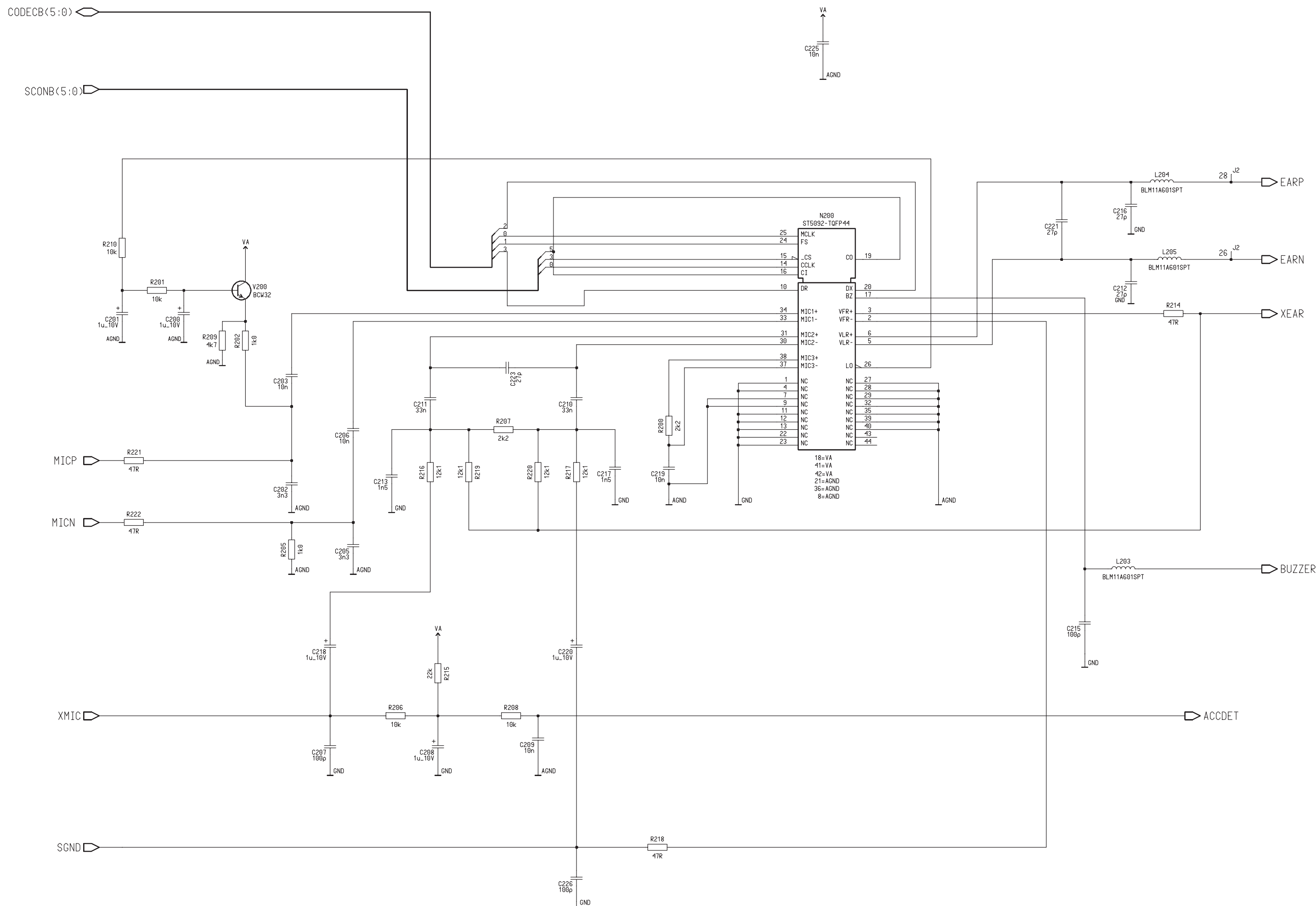



CPU Circuit Diagram v.3.5 ed.18

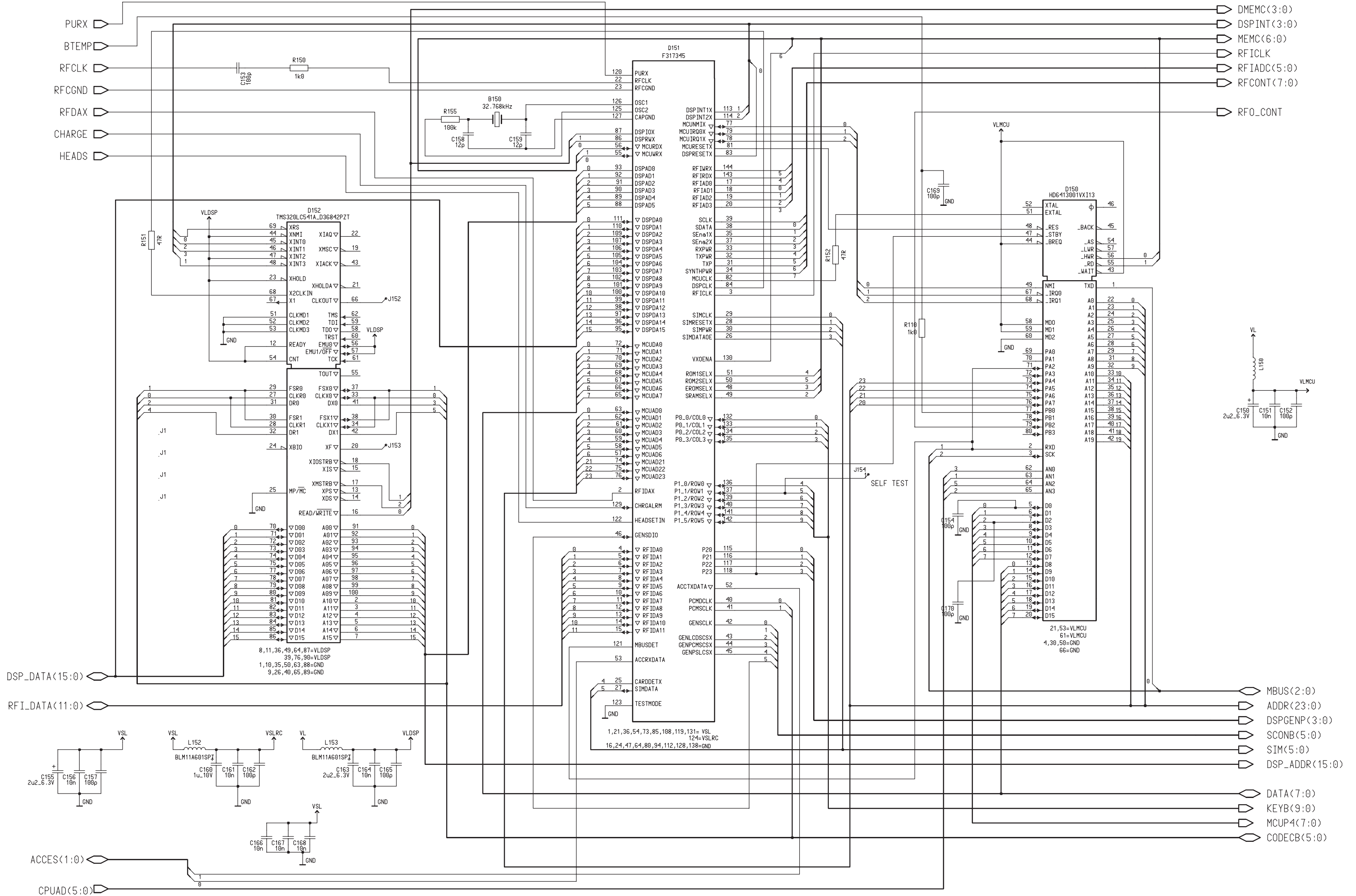

DSP Circuit Diagram v.3.5 ed.52

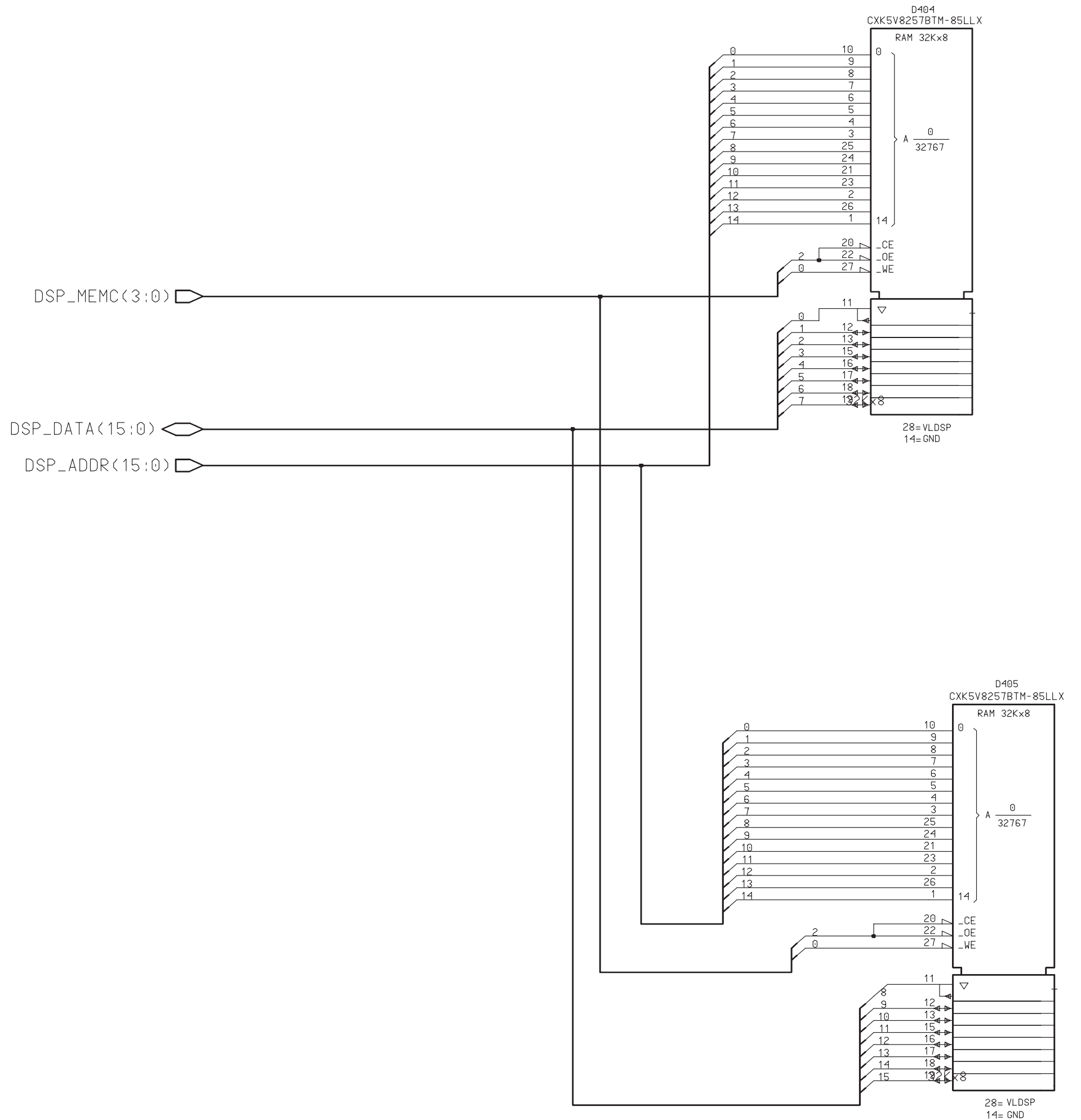
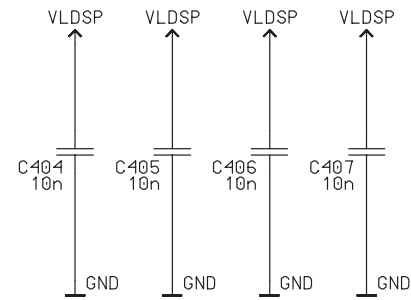

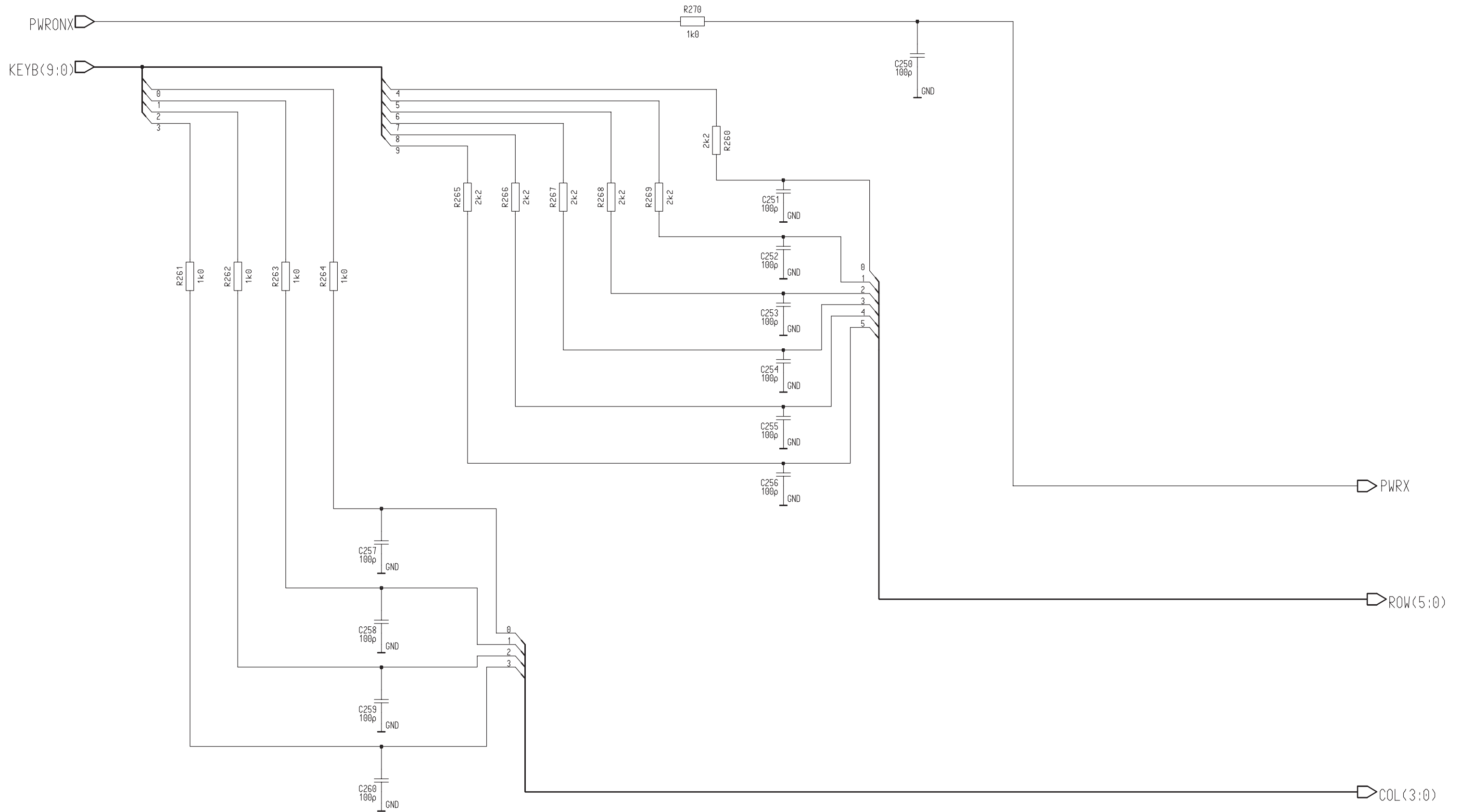

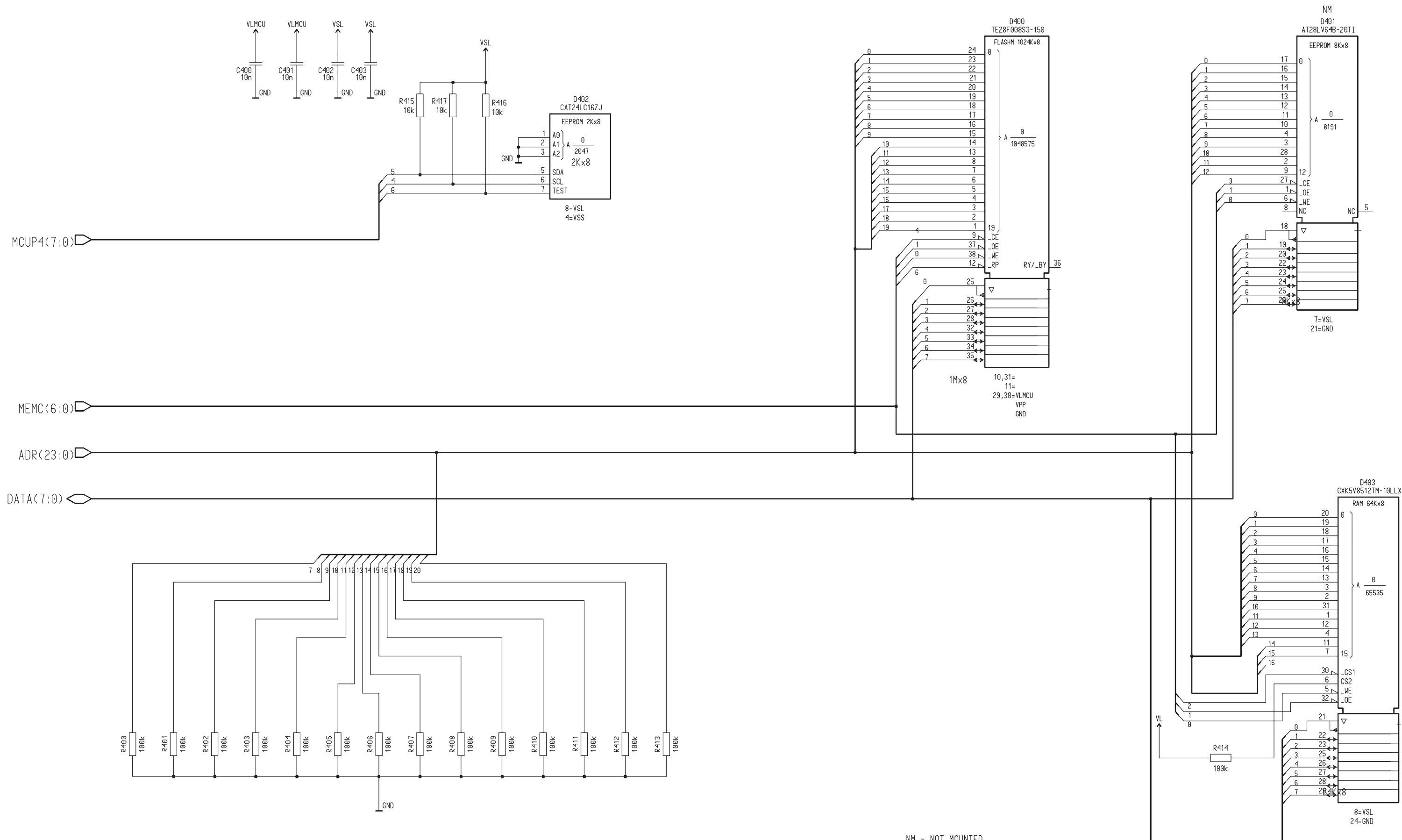

NM = NOT MOUNTED

Power Supply / Charging Circuit Diagram v.3.5 ed.153

